

TABLE 1: ELECTRICAL SPECIFICATIONS AT 25 °C

SWITCHING TRANSFORMER DESIGNED FOR USE WITH POWER INTEGRATIONS
TOP-224Y REFER TO APPLICATION CIRCUIT OF FIGURE 3.

PARAMETER	SPEC LIMITS			UNITS
	MIN.	TYP.	MAX.	
PRIMARY INDUCTANCE (2-1) FREQ. = 100 KHZ @ 0.250Vrms	517	575	633	μHY
TURNRATIO'S: BIAS (3-4) : PRIMARY (2-1) SEC #1A (8-7) : PRIMARY (2-1) SEC #1B (10-9) : PRIMARY (2-1) SEC #2 (6-5) : PRIMARY (2-1)	---	1: 8.545 1: 6.714 1: 6.714 1:15.667	---	± 4% ± 4% ± 4% ± 4%
PRI LEAKAGE (10 THRU 5 SHORTED) FREQ. = 100 KHZ @ 0.250Vrms	---	---	18.0	μHY
HIPOT: PRIMARY TO SECONDARY BIAS TO SECONDARY	3000 3000	---	---	Vrms Vrms
APP CIRCUIT PARAMETERS: (1) AC LINE VOLTAGE RECTIFIED DC INPUT VOLTAGE SEC #1 OUTPUT VOLTAGE SEC #1 OUTPUT CURRENT SEC #2A & 2B OUTPUT VOLTAGE SEC #2A & #2B OUTPUT CURRENT	85 80 ---	---	265 375 ---	Vac Vdc mA ±Vdc ±mA

(1) REFER TO APPLICATION CIRCUIT OF FIGURE 3.

FIGURE 1: SCHEMATIC DIAGRAM

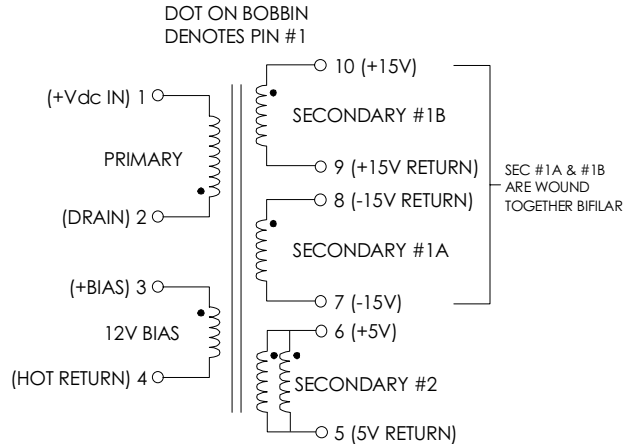

NOTE 1: REINFORCED INSULATION SYSTEM, UL1950, IEC950, CSA-950:

- A) ALL MATERIALS MEET "UL", "CSA" & "IEC" REQUIREMENTS
- B) TRIPLE BASIC INSULATED SECONDARY.
- C) DESIGNED TO MEET ≥6.2mm CREEPAGE REQUIREMENTS.
- D) VARNISH FINISHED ASSEMBLY.
- E) UL1950 & CSA-950 CERTIFIED: FILE #E162344.
- F) UL CLASS (B) 130 INSULATION SYSTEM PM130-H1A (UL FILE #E177139) OR ANY UL AUTHORIZED CLASS (B) INSULATION SYSTEM.

FIGURE 2: PHYSICAL DIMENSIONS mm (INCHES)

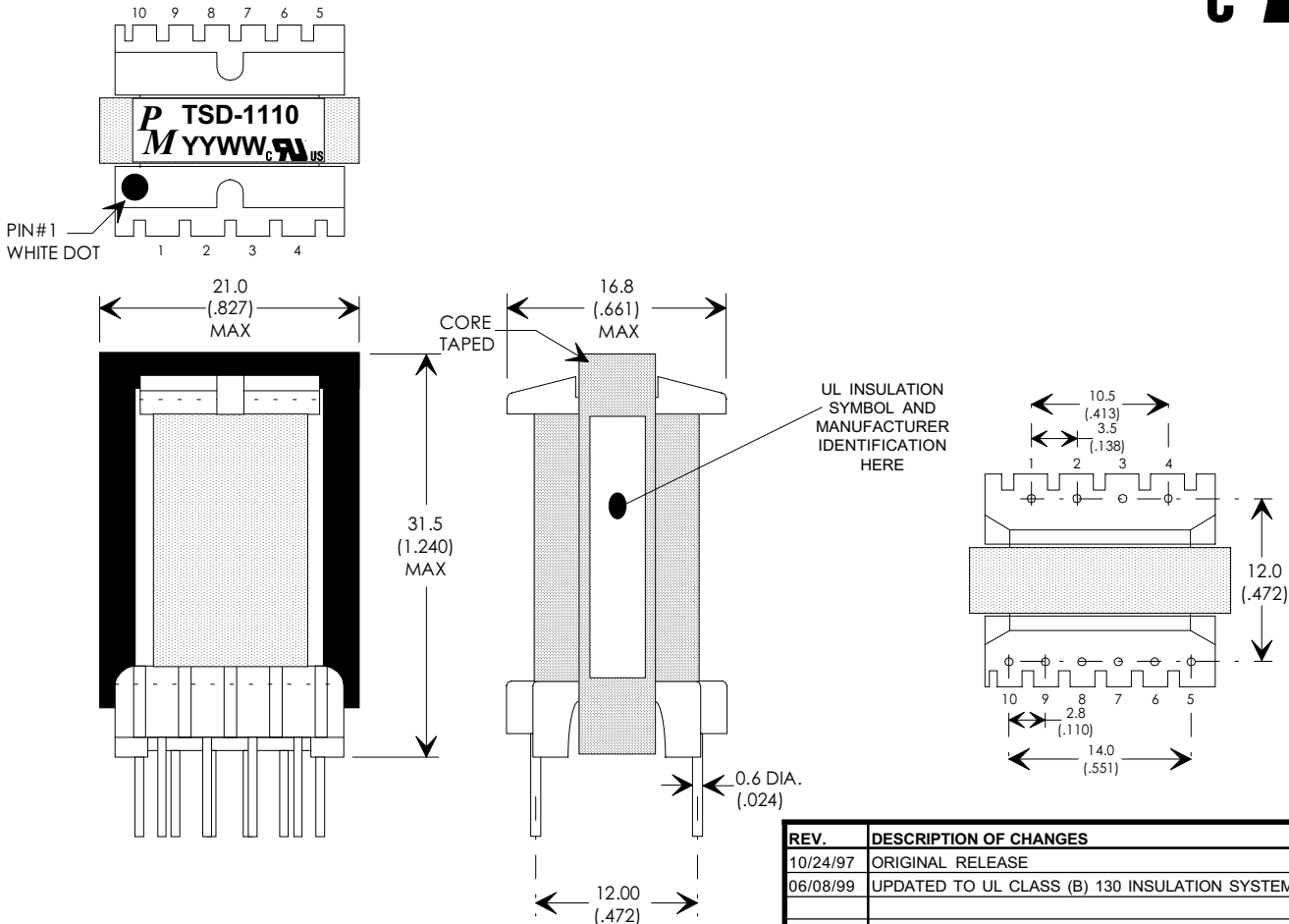

EEL19, 10-PIN VERTICAL



UNLESS OTHERWISE SPECIFIED
DIMENSIONS ARE IN MM
DIMENSIONAL TOLERANCES ARE:
DECIMALS ANGLES
.X ± .25 ±0° 30'
.XX ± .15
DO NOT SCALE DRAWING

REV.	DESCRIPTION OF CHANGES	BY
10/24/97	ORIGINAL RELEASE	TO
06/08/99	UPDATED TO UL CLASS (B) 130 INSULATION SYSTEM	MD

FLYBACK TRANSFORMER CONTROL DRAWING	
PREMIER P/N: TSD-1110	REVISION: 06/08/99
DRAWN BY: TOM O'NEIL	REF: TOP224Y
SCALE: NONE	SHEET: 1 OF 4

APPLICATION NOTES

Premier Magnetic's TSD-1110 Switch Mode Transformer was designed for use with Power Integrations, Inc. TOP224Y three terminal off-line PWM switching regulator in the Flyback Buck-Boost circuit configuration. This conversion topology can provide isolated multiple outputs with efficiencies up to 90%. Premier's TSD-1110 transformer has been optimized to provide maximum power throughput.

The TOPXXX series from Power Integrations, Inc. are self contained 100KHz three terminal voltage controlled PWM switching regulators. This series contains all necessary functions for an off-line switched mode control DC power source. These switching regulators provide a very simple solution to off-line designs. The inductors and transformer used with the PWR-TOPXXX are critical to the performance of the circuit. They define the overall efficiency, output power and overall physical size.

Below is a universal input high precision 20 watt application circuit utilizing Power Integrations TOP224Y switching regulator in the flyback buck-boost configuration. Proper thermal management of the TOP224Y, VR1 & D3 is required for reliable operation. As with any flyback circuit the output is not intended to be run under a no load condition. Careful evaluation by the end user is required and should be based on the actual application & it's associated environmental conditions. The component values listed are intended for reference purposes only.

FIGURE 3: TYPICAL APPLICATION CIRCUIT

PREMIER MAGNETICS PART NUMBERS:
(REQUEST DATA SHEETS BY PART#)

- L1 = PMCU-0330 33mHy EMI/RFI CMC
- T1 = TSD-1110 MAIN SWITCHING TRANSFORMER
- L2 = VTP-01002 10uHy, 1.0Amp INDUCTOR

ALUMINUM ELECTROLYTIC FILTER CAPACITOR RATINGS:

- ±15V OUTPUT: C10 & C12 ≥25V, Ripple Rated ≥ 235mA @ 100KHz @ Max. Op. Temp.
- +5.V OUTPUT: C2 ≥10V, Ripple Rated ≥ 2350mA @ 100KHz @ Max. Op. Temp.

PANASONIC FA SERIES:

- C2 = 1500uF, 25V = PANASONIC EEUFA1E152L
- C10, C12, C3 = 220uF, 25V = PANASONIC ECEA1EFG221
- C11, C13 = 100uF, 25V = PANASONIC ECEA1EFG101

